

STILT FLOOR PLAN

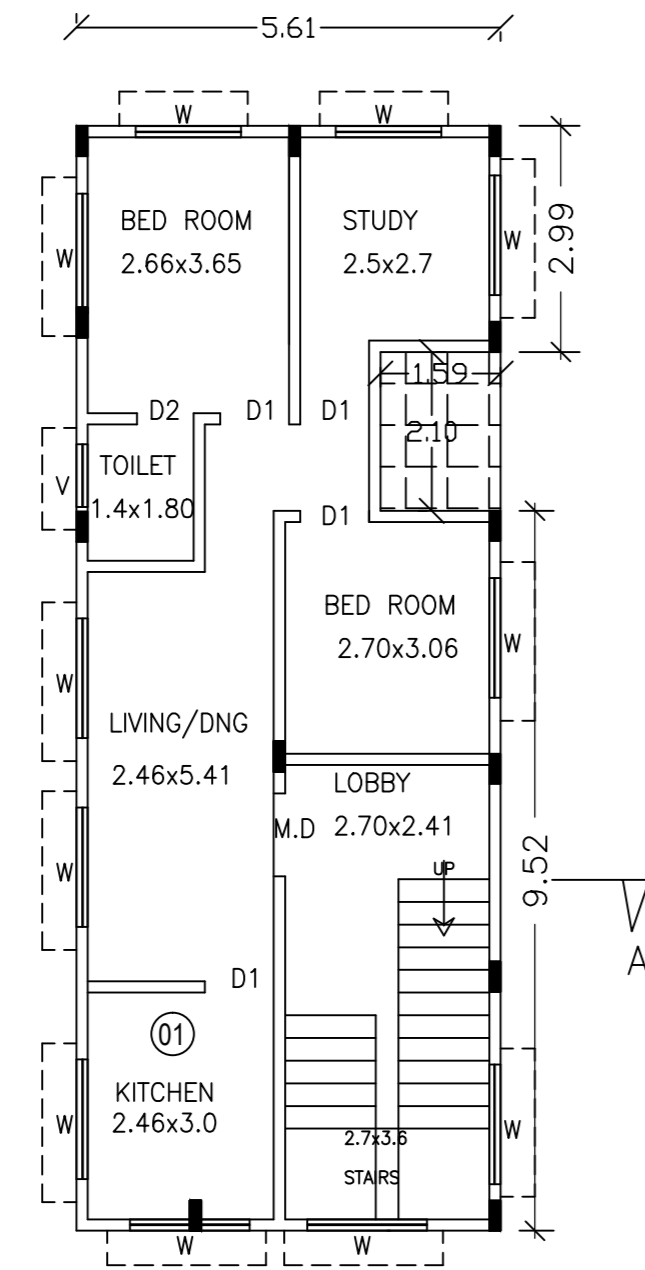

GROUND FLOOR PLAN

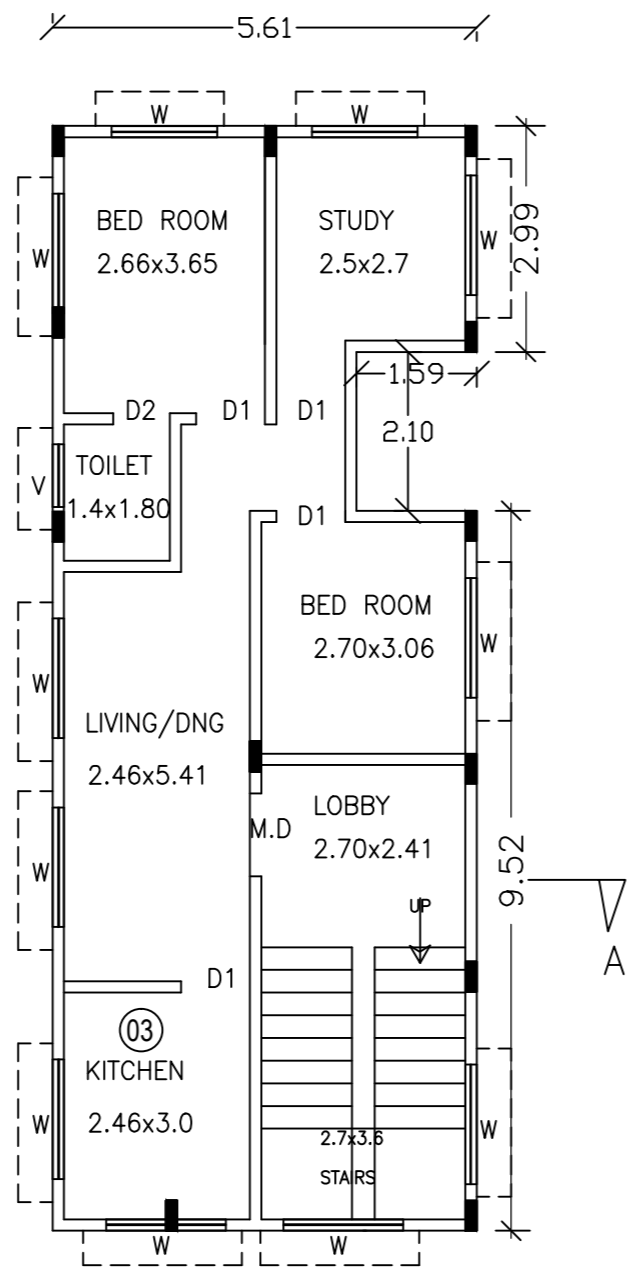

FIRST FLOOR PLAN

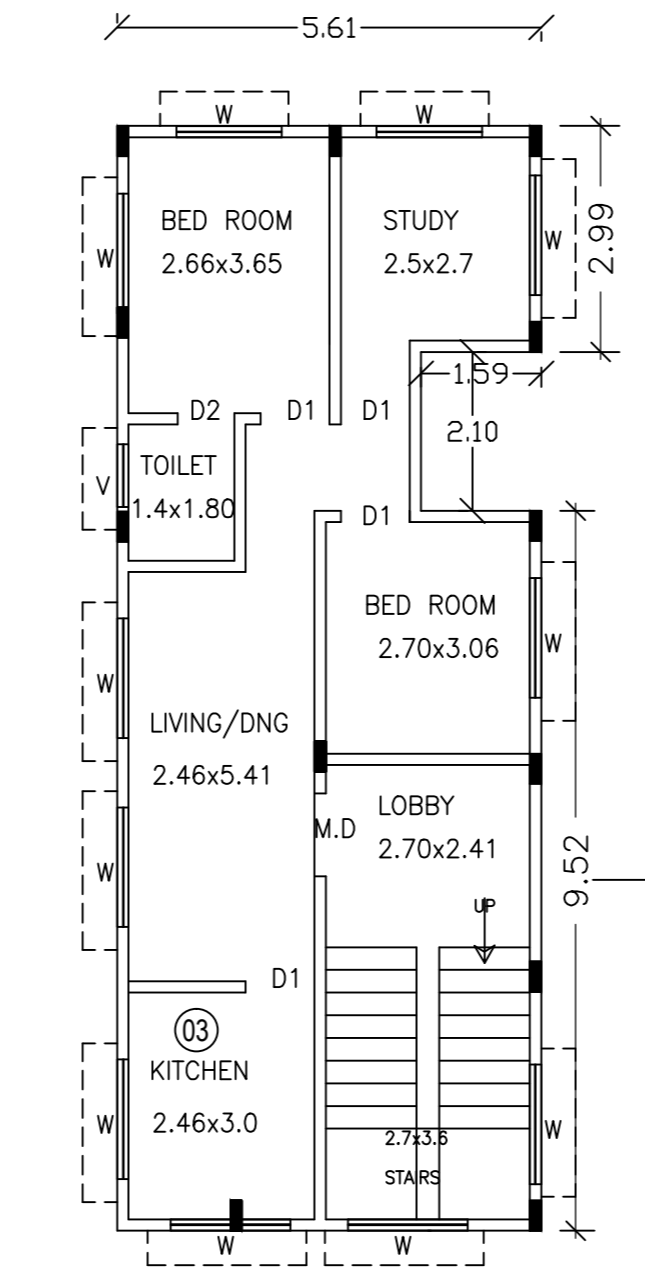

SECOND FLOOR PLAN

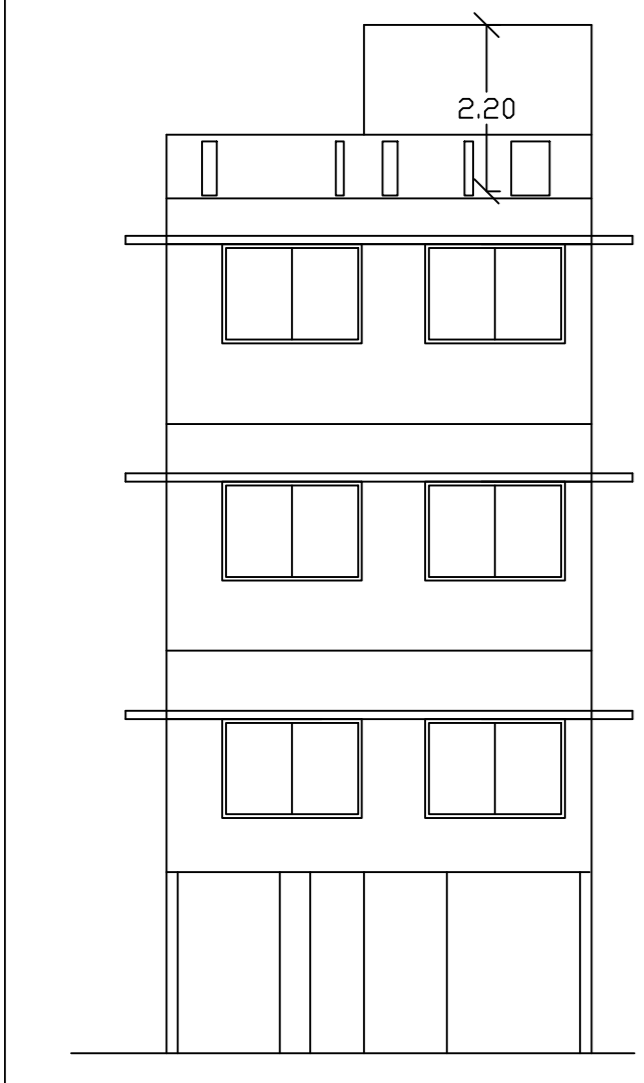

FRONT ELEVATION

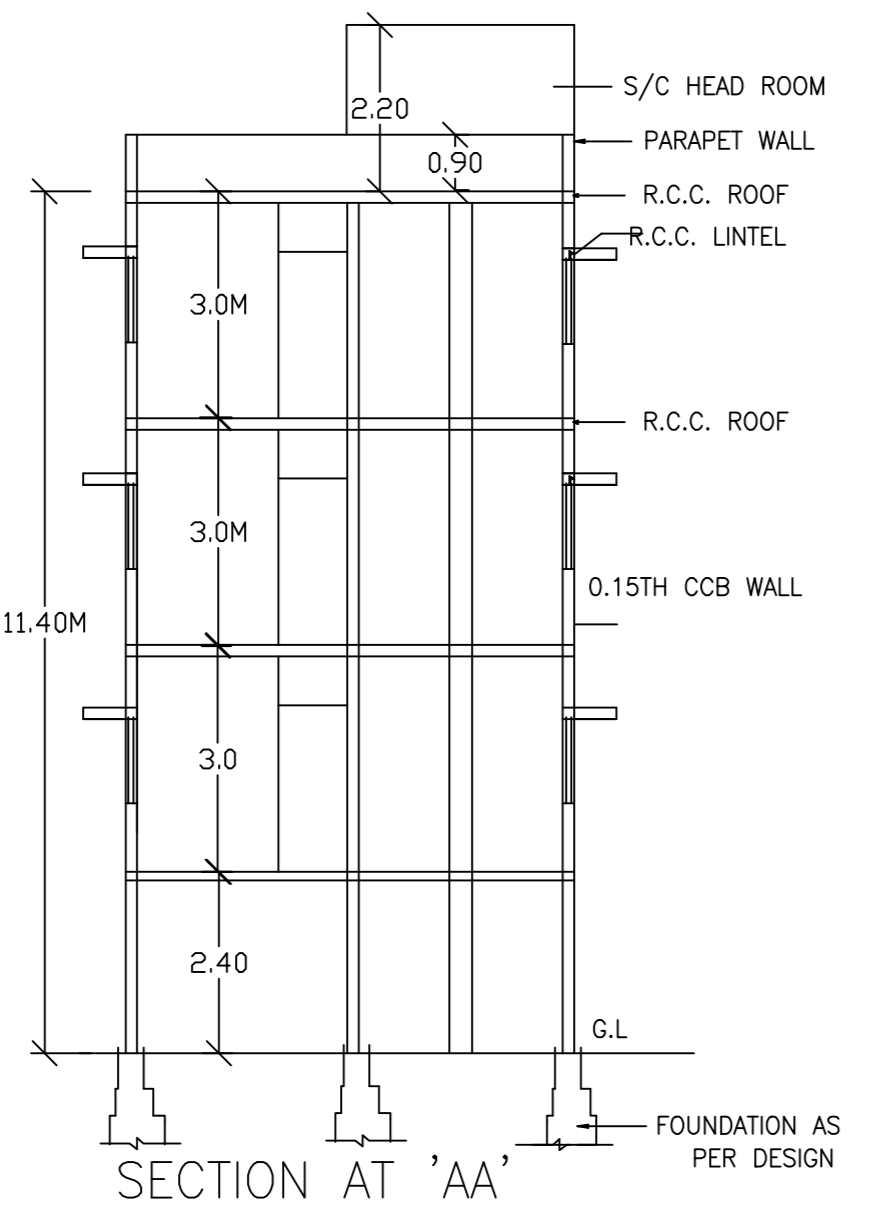

SECTION AT 'AA'

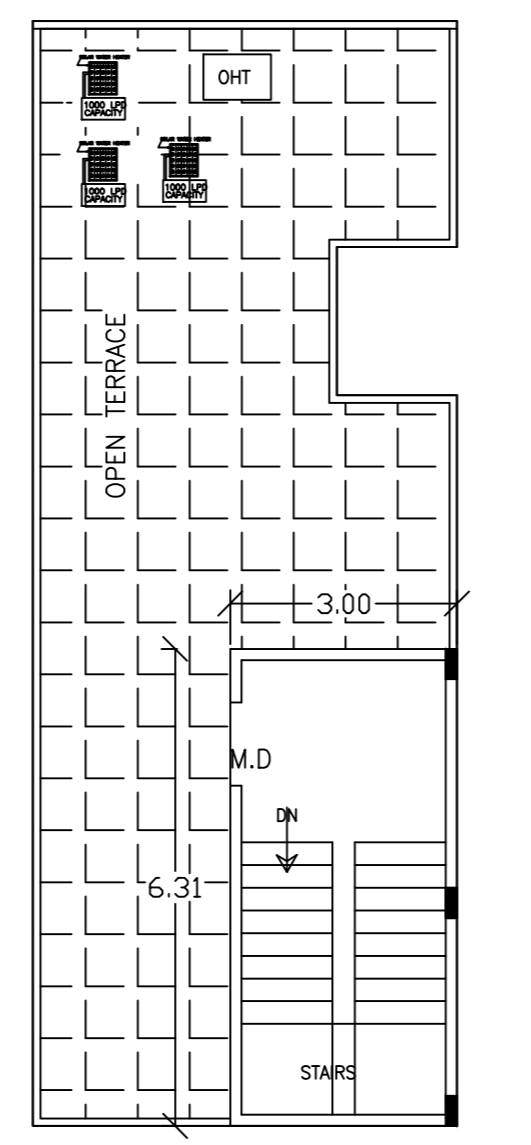

TERRACE FLOOR PLAN

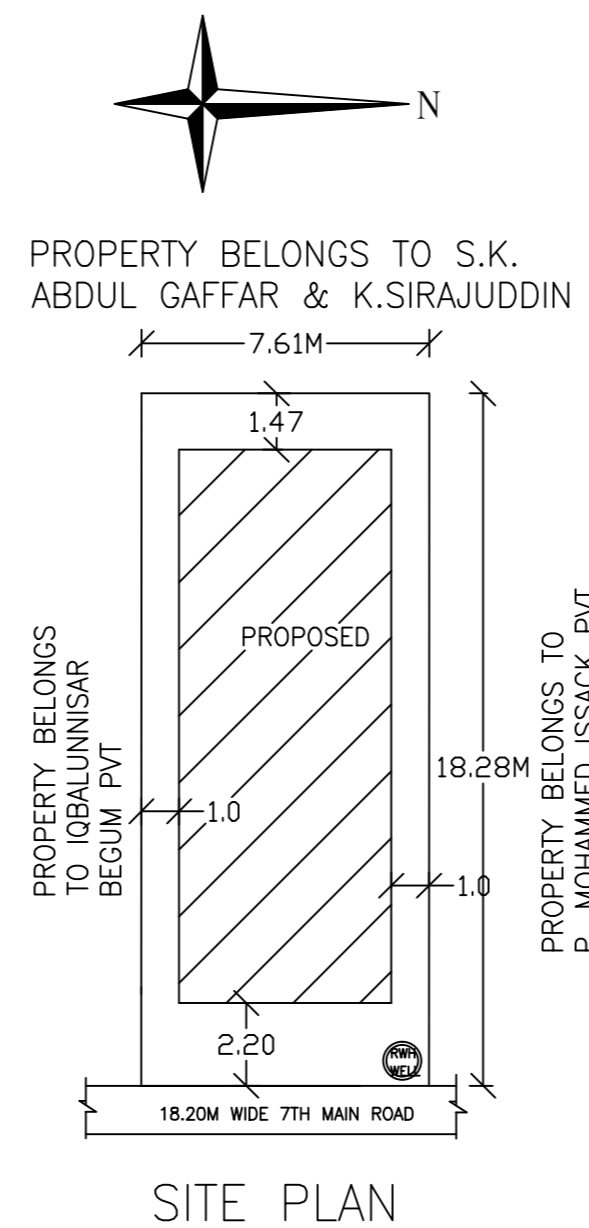

SITE PLAN

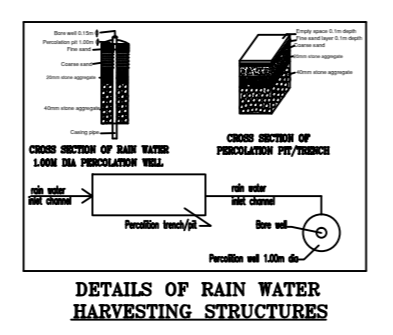

DETAILS OF RAIN WATER HARVESTING STRUCTURES

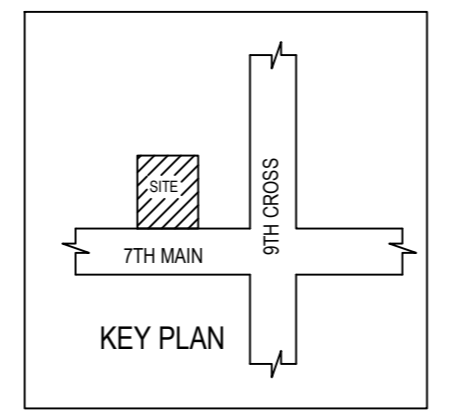

KEY PLAN

ಅಂತರ್ಜಾಲ ತಂತ್ರಾಂಶ ಮುಖಾಂತರ ನಕ್ಷೆ ಮಂಜೂರಾತಿ ನೀಡಿದೆ

“ಸುವರ್ಣ ಪರವಾನಿಗೆ”

ಸೂಚನೆ/ಪರತ್ತು

- ಈ ಸ್ಥಳದ ಮಾಲೀಕತ್ವದ ಬಗ್ಗೆ ಬೆಂಗಳೂರು ಅಭಿವೃದ್ಧಿ ಪ್ರಾಧಿಕಾರ, ಅಥವಾ ಬೇರೆ ಯಾರಿಂದಲಾದರೂ ತಕರಾರು ಬಂದಲ್ಲಿ ಅಥವಾ ನ್ಯಾಯಾಲಯದ ಆದೇಶಗಳೇನಾದರೂ ಬಂದಲ್ಲಿ ಈ ಮಂಜೂರಾತಿ ನಕ್ಷೆಯನ್ನು ರದ್ದುಪಡಿಸಲಾಗುವುದು.
- ಈ ನಕ್ಷೆ ಮಂಜೂರಾತಿಯು ಪಾಲಿ ಇರುವ ಕಟ್ಟಡವನ್ನು ಕ್ರಮಬದ್ಧಗೊಳಿಸುವುದಿಲ್ಲ.
- ಸ್ಥಳದ ಮಾಲೀಕರು ತಮ್ಮ ನಿವೇಶನದಿಂದ/ಕಟ್ಟಡದಿಂದ ಬರುವ ಮಳೆನೀರನ್ನು ಸಂರಕ್ಷಿಸಿ ಮಳೆ ನೀರನ್ನು ಕೊಯ್ಲು ಮಾಡತಕ್ಕದ್ದು. ಕಡ್ಡಾಯವಾಗಿ ಅಳವಡಿಸುವುದು ಮತ್ತು ತ್ಯಾಜ್ಯ ನೀರನ್ನು ರಸ್ತೆಗೆ ಹೋಗದಂತೆ, ನಿವೇಶನದ ಮುಂಭಾಗದ ಚರಂಡಿಗೆ ಮೇಲ್ಭಾಗದಲ್ಲಿ ಕಬ್ಬಿಣದ ಗ್ರೇಟಿಂಗ್ ಅಳವಡಿಸಿ ಕಟ್ಟುನಿಟ್ಟಾಗಿ ನೀರನ್ನು ಚರಂಡಿಗೆ ಹೋಗಲು ಅನುವು ಮಾಡಿಕೊಡುವುದು. ತಪ್ಪಿದಲ್ಲಿ ಕೆ.ಎಂ.ಸಿ. ನಿಯಮಾವಳಿ 1976ರ ಪ್ರಕಾರ ಕ್ರಮ ಕೈಗೊಳ್ಳಲಾಗುವುದು.
- ಸ್ಥಳದ ಅಂತಸ್ತನ್ನು ವಾಪಸು ನಿಲುಗಡೆಯ ಉದ್ದೇಶಕ್ಕಾಗಿ ಮಾತ್ರ ಬಳಸತಕ್ಕದ್ದು. ಹಾಗೂ ಯಾವುದೇ ಕಾರಣಕ್ಕಾಗಿ ಸ್ಥಳದ ಅಂತಸ್ತನ್ನು ಬೇರೆ ಉದ್ದೇಶಕ್ಕಾಗಿ ಬಳಸಬಾರದು.
- ಸ್ಥಳದ ಮಾಲೀಕರು ತಮ್ಮ ಕಟ್ಟಡಕ್ಕೆ ಪಡೆಯುವ ಕುಡಿಯುವ ನೀರಿನ ಸಂಪರ್ಕ/ಒಳಚರಂಡಿ/ವಿದ್ಯುತ್ ಸಂಪರ್ಕ ಕೊಳವೆಗಳನ್ನು/ ಕೇಬಲ್‌ಗಳನ್ನು, ಕಟ್ಟುನಿಟ್ಟಾಗಿ ಚರಂಡಿಯ ತಳ ಭಾಗದಲ್ಲಿಯೇ ಕೊಂಡೊಡೆಯುವುದು ತಪ್ಪಿದಲ್ಲಿ ಕೆ.ಎಂ.ಸಿ. ನಿಯಮಾವಳಿ 1976ರ ಪ್ರಕಾರ ಕ್ರಮ ಕೈಗೊಳ್ಳಲಾಗುವುದು.
- ಉದ್ದೇಶಿತ ಯೋಜನೆಯಲ್ಲಿ ಕಾರ್ಯನಿರ್ವಹಿಸುವ ಕಾರ್ಮಿಕರನ್ನು ಕಾರ್ಮಿಕ ಇಲಾಖೆಯ ಕಾರ್ಮಿಕ ಅಧಿಕಾರಿಗಳ ಕಛೇರಿಯಲ್ಲಿ ಕಡ್ಡಾಯವಾಗಿ ನೋಂದಾಯಿಸತಕ್ಕದ್ದು.
- The Building & Other Construction Workers (Regulations Of Employment & Conditions of Service) Central Rules 1988ರ ಭಾಗ -3ರ ಅರೋಗ್ಯ ಮತ್ತು ಸುರಕ್ಷತೆಯ ಅಧ್ಯಾಯ 7 ರಿಂದ 25 ರಲ್ಲಿನ ಕುರಿತು ಇರುವ ನಿಯಮಗಳನ್ನು ಪಾಲಿಸತಕ್ಕದ್ದು.
- ಕಾರ್ಮಿಕ ಕಲ್ಯಾಣ ಇಲಾಖೆಯಿಂದ ನಿಗದಿಪಡಿಸಲಾಗಿರುವ ಸುರಕ್ಷತೆಯ ಕ್ರಮಗಳನ್ನು, ತಪ್ಪದೇ ಅಳವಡಿಸುವುದು. ತಪ್ಪಿದಲ್ಲಿ ಕಾನೂನು ರೀತ್ಯಾ ಪರವಾನಗಿಯನ್ನು ತಕ್ಷಣದಿಂದ ಹಿಂತೆಗೆಯಲಾಗುವುದು.
- After laying of foundation concrete, column and plinth as per Drawing, further work should commence only after obtaining COMMENCEMENT CERTIFICATE from the Bruhat Bangalore Mahanagara Palike after inspection from the Asst. Director of Town Planning.
- The Applicant shall provide at least one toilet in the Ground Floor for the use of the visitors/servants/drivers and security-men. The Occupation Certificate will be considered after ensuring the same is provided in the building.
- THE OWNER / BUILDER SHOULD ENSURE THE REQUIRED SAFETY MEASURES WHILE EXCAVATION FOR BASEMENT/ FOUNDATION AND CONSTRUCTING THE BASEMENT/ FOUNDATION/STILT AND UPPER FLOORS WITH REGARD TO THE STABILITY OF THE STRUCTURE, SAFETY OF THE NEIGHBOURS AND CONSTRUCTION LABOURERS. OWNER/ BUILDER WILL BE HELD RESPONSIBLE FOR ANY LAPSES IN THIS REGARD.

Office Of The Additional/Joint Commissioner (South)
(Bruhat Bengaluru Mahanagara Palike)
LP No: Ad.com/SUT /0635/18-19
Valid From _____ to _____
for two years, sanctioned as per plan / as corrected in green.

AREA STATEMENT (BBMP)	VERSION NO.: 1.0.9
	VERSION DATE: 18/05/2018
PROJECT DETAIL:	
Authority: BBMP	Plot Use: Residential
Inward No: BBMP/Ad.Com./SUT/0635/18-19	Plot SubUse: Residential
Application Type: Suvarna Parvangi	Land Use Zone: Residential (Main)
Proposal Type: Building Permission	Plot/Sub Plot No.: 199/3
Nature of Sanction: New	PID No. (As per Khata Extract): 50-70-199/3
Location: Ring-II	Locality / Street of the property: R V ROAD, BANGALORE.

AREA DETAILS:		SQ.MT.
AREA OF PLOT (Minimum)	(A)	139.14
NET AREA OF PLOT	(A-Deductions)	139.14
COVERAGE CHECK		
Permissible Coverage area (75.00 %)		104.35
Proposed Coverage Area (51.79 %)		72.06
Achieved Net coverage area (51.79 %)		72.06
Balance coverage area left (23.21 %)		32.29
FAR CHECK		
Permissible F.A.R. as per zoning regulation 2015 (1.75)		243.49
Additional F.A.R within Ring I and II (for amalgamated plot -)		0.00
Allowable TDR Area (60% of Perm.FAR)		0.00
Allowable max. F.A.R Plot within 150 Mt radius of Metro station (-)		0.00
Total Perm. FAR area (1.75)		243.49
Residential FAR		242.00
Proposed FAR Area		242.00
Achieved Net FAR Area (1.74)		242.00
Balance FAR Area (0.01)		1.49
BUILT UP AREA CHECK		
Proposed BuiltUp Area		326.91
Achieved BuiltUp Area		326.91

COLOR INDEX	
PLOT BOUNDARY	_____
EXISTING STREET	_____
PERM. BUILDING LINE	_____
EXISTING (To be retained)	_____
EXISTING (To be demolished)	_____
PROPOSED	_____

ARCH / ENGG / SUPERVISOR (Regd)	OWNER SIGN
	1) HEENA KAUSAR
	2) TARANUM ARA KAUSAR
	3) FAREEN ARA KAUSAR WARIS ALI SHAIKH

OWNER'S NAME:	OWNER'S SIGN
HEENA KAUSAR AND OTHERS	

PROJECT DESCRIPTION::
- PLAN SHOWING PROPOSED RESIDENTIAL BUILDING ON PROPERTY NO-199/3, R V ROAD, BANGALORE, WARD NO -153 (OLD NO-50), PID NO:50-70-199/3

ARCHITECT:	ARCHITECT SIGN:
MEHBOOB BASHA	

JOB NO.	DRG.NO.	SCALE	DRAWN BY	CHECKED BY
		1:100		

Block Name	Block Use	Block SubUse	Block Structure	Block Land Use Category
A (RESIDENTIAL)	Residential	Residential	Bldg upto 11.5 mt. Ht.	R

Block Name	Type	SubUse	Area (Sq.mt.)	Units		Car	
A (RESIDENTIAL)	Residential	Residential	50 - 225	Reqd.	Prop.	Reqd./Unit	Prop.
				1	-	1	3
Total:				-	-	-	3

Vehicle Type	Reqd.		Achieved	
	No.	Area (Sq.mt.)	No.	Area (Sq.mt.)
Car	3	41.25	3	41.25
Total Car	3	41.25	3	41.25
Other Parking	-	-	-	24.73
Total		41.25		65.98

Block	No. of Same Bldg	Total Built Up Area (Sq.mt.)	Deductions (Area in Sq.mt.)		Proposed FAR Area (Sq.mt.)	Total FAR Area (Sq.mt.)	Tnmt (No.)
A (RESIDENTIAL)	1	326.91	StairCase	Parking	Resi.		
			18.93	65.98	242.00	242.00	03
Grand Total:	1	326.91	18.93	65.98	242.00	242.00	03

Floor Name	Total Built Up Area (Sq.mt.)	Deductions (Area in Sq.mt.)		Proposed FAR Area (Sq.mt.)	Total FAR Area (Sq.mt.)	Tnmt (No.)
		StairCase	Parking	Resi.		
Terrace Floor	18.93	18.93	0.00	0.00	0.00	00
Second Floor	78.64	0.00	0.00	78.64	78.64	01
First Floor	78.64	0.00	0.00	78.64	78.64	01
Ground Floor	78.64	0.00	0.00	78.64	78.64	01
Stilt Floor	72.06	0.00	65.98	6.08	6.08	00
Total:	326.91	18.93	65.98	242.00	242.00	03

SCHEDULE OF JOINERY:					
BLOCK NAME	NAME	LENGTH	HEIGHT	NOS	
A (RESIDENTIAL)	D2	0.75	2.10	03	
A (RESIDENTIAL)	D1	0.91	2.10	12	
A (RESIDENTIAL)	M.D	1.10	2.10	03	
SCHEDULE OF JOINERY:					
BLOCK NAME	NAME	LENGTH	HEIGHT	NOS	
A (RESIDENTIAL)	V	1.00	0.60	06	
A (RESIDENTIAL)	W1	1.50	1.20	06	
A (RESIDENTIAL)	W	2.20	1.20	33	

OWNER POSTAL ADDRESS:
NO - 15, 1ST PHASE, 2ND MAIN WEST CHORD ROAD, RAJAJINAGAR, BANGALORE-560010.